

SCHEMATIC

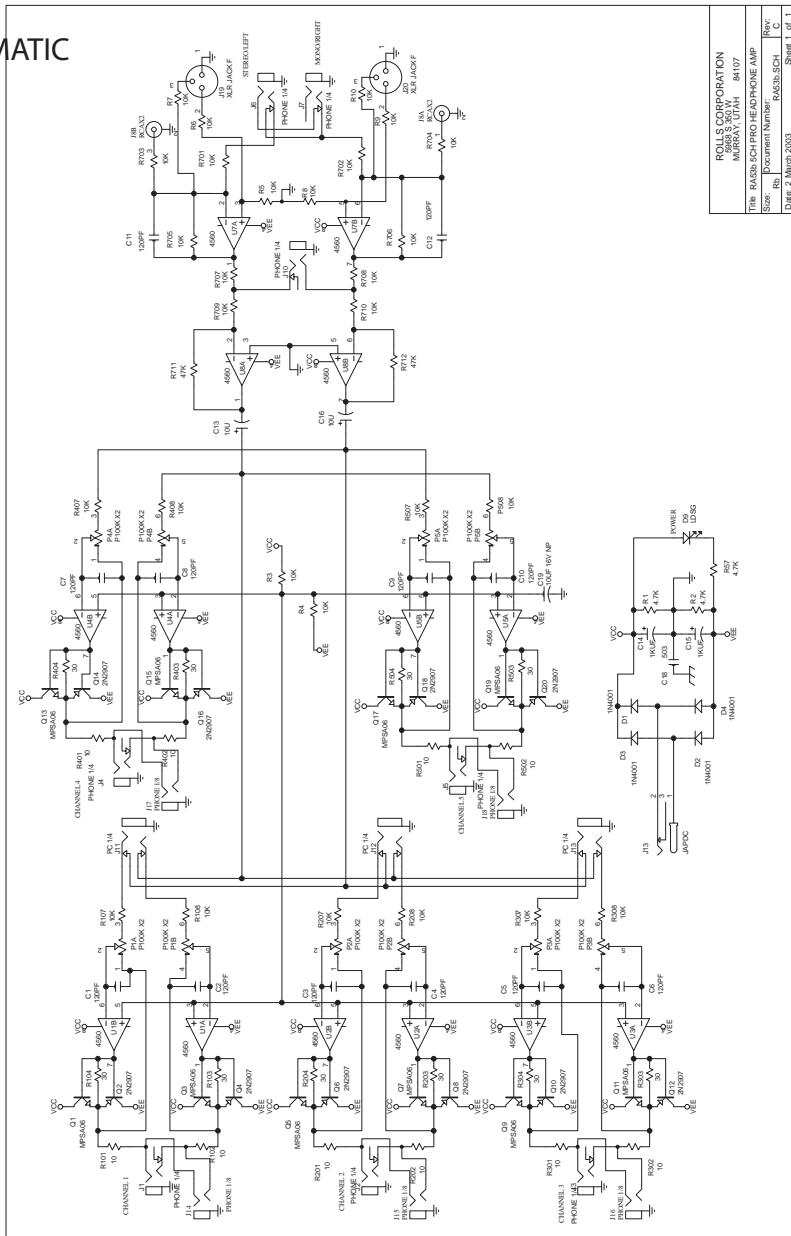

RA53b Headphone Amp



ROLLS

ROLLS CORPORATION
SALT LAKE CITY, UTAH
06/2011

ROLLS

RA53b

Stereo Headphone Amplifier

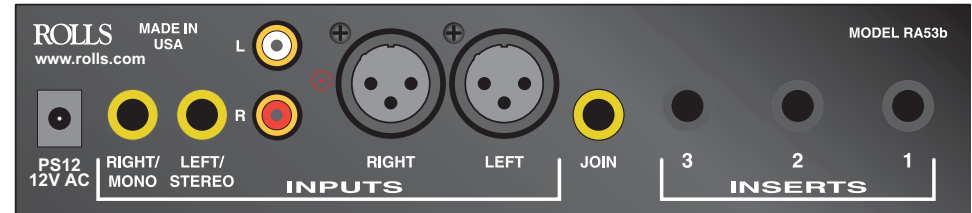
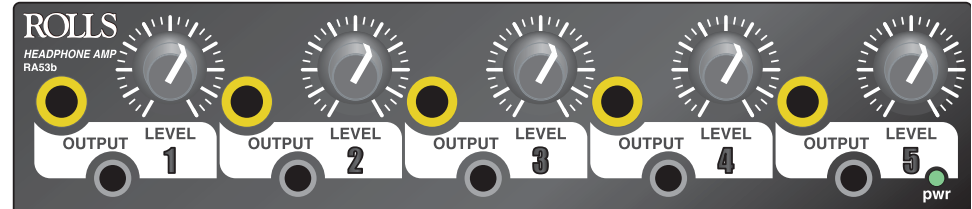

SPECIFICATIONS

- Input Impedance: 10 K ohms
- Max Input Level: +18 dBV
- Max Gain: 26 dB per channel
- Output Power: 221 mW per side, 442 mW per channel (@ 32 Ohms)
- Output Impedance: 10 Ohms
- S/N Ratio: >90 dB
- THD: <.08%
- IMD (SMPTE): <.08%
- Power: ROLLS PS12 - 12V AC (Adapter Provided)
- Size: 8.4" x 1.7" x 5" (21.3 x 4.3 x 13 cm)
- Weight: 2.5 lbs (1.14 kg)

INTRODUCTION

Thank you for your purchase of the Rolls RA53b Stereo Headphone Amplifier. This unit was designed to provide years of dependable service. Please read this manual carefully to ensure proper operation.

The RA53b is a five-channel headphone/earphone amplifier with a variety of input options. In addition to the four master mix inputs, four separate mixes may be monitored using the main inputs and the three Insert jacks on Channels 1, 2, and 3.

A 1/4" JOIN Input/Output jack is provided for connecting two RA53b units together, providing up to ten channels of headphone monitoring.

Finally - the RA53b is loud. It has plenty of gain for operation in noisy environments, and works with most any headphone impedance.

INSPECTION

Unpack and inspect the RA53b box and package.

If obvious physical damage is noticed, contact the carrier immediately to make a damage claim. We suggest saving the shipping carton and packing materials for safely transporting the unit in the future.

WARRANTY

For complete Warranty information and registration, please visit our website; www.rolls.com. Click on the REGISTER YOUR WARRANTY HERE line. Or, complete the Warranty Registration Card and return it to the factory.

CONNECTION

Connect the Rolls Power Supply to the POWER jack on the RA53b rear panel. Connect the power supply to an ac outlet.

Determine which input configuration you will use; either discreet right/left, TRS stereo, or mono.

For a discreet right/left input configuration, connect a 1/4" TS plug containing the "Right" portion of the stereo signal to the Right/Mono Input. Connect a 1/4" TS plug containing the "Left" portion of the stereo signal to the Left/Stereo Input.

If connecting a balanced signal, use the XLR inputs instead of the 1/4" inputs and connect as indicated above.

For a TRS stereo input configuration, connect a Tip-Ring-Sleeve stereo plug into the Left/Stereo input. This cable may come from a mixer's headphone output for example. Make sure nothing is connected to the Right/Mono Input.

To send a mono signal to the RA53b, connect a 1/4" Tip-Sleeve plug into the Right/Mono Input. This mono signal will be fed to both the right and left sides of the headphone outputs. Make sure nothing is connected to the Left/Stereo Input.

The RCA Aux Inputs are connected in the same manner as the discreet right/left input configuration listed above.

To link another RA53b, simply connect a 1/4" TRS stereo cable to both JOIN jacks on two RA53b units.

INSERTS

The Channel 1, 2 and 3 inserts have been provided so you can directly access Channel 1, Channel 2 and Channel 3 headphone and earphone outputs with their own program material.

The inserts require Tip-Ring-Sleeve connectors, with right and left signals on the tip and ring respectively.

When these insert jacks are used, the main Right/Stereo and Left/Mono, as well as the RCA and XLR Inputs - are disconnected to that channel. Only the stereo signals sent to the Insert jacks go to the corresponding outputs.

FRONT PANEL

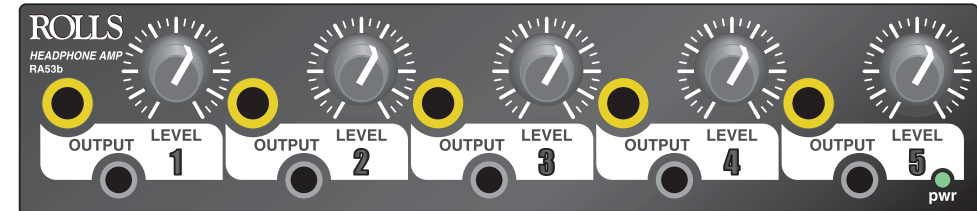

Note: Descriptions for Channel One through Channel Five are identical.
OUTPUT: 1/4" and 1/8" (3.5mm) Tip-Ring-Sleeve jacks for connection to a standard pair of headphones or earphones. Output impedance is 10 Ohms.
LEVEL: Controls the amount of output signal from the indicated channel.

POWER LED: Indicates that the RA53b is connected to the power supply and is on.

REAR PANEL

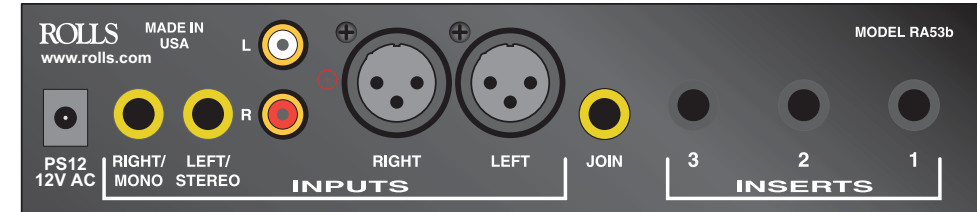

POWER: For connection to a Rolls #PS12 - 12V AC power supply ONLY!!!

RIGHT/MONO INPUT: 1/4" TS jack for connecting the "Right" side of a stereo signal. If used alone (nothing connected to the LEFT/STEREO jack), a 1/4" TS plug with a mono signal will feed both sides of the RA53b Outputs.

LEFT/STEREO INPUT: 1/4" TRS jack for connecting to the "Left" side of a stereo signal. If used alone, (nothing connected to the RIGHT/MONO jack) a 1/4" TRS plug with the "Right" side of the program material on the tip, and the "Left" side on the ring may be connected for stereo operation. For example, a stereo headphone output from a mixing console may be directly connected to the Left/Stereo jack via a stereo TRS cable.

L /R INPUTS: RCA input jacks for connection to a signal source such as a CD or cassette player.

BALANCED INPUTS: XLR input jacks for connection to a balanced line level source such as the output of a mixer.

JOIN: 1/4" TRS jack for connection to another RA53b JOIN jack. Linking two units together provides 10 channels of monitoring from a master stereo signal, with six channels having an insert option.

CHANNEL INSERTS: 1/4" TRS jacks for receiving a stereo signal and directly accessing the indicated channel's circuitry.